

# Yanmar type 4LHA-DTP

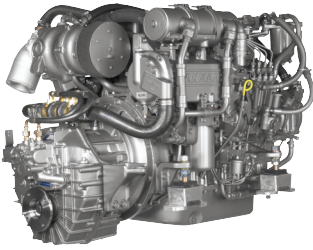

<b>Configuration</b>	4-stroke, vertical, water cooled diesel engine
<b>Maximum output at crankshaft</b>	* 147 kW (200 mhp) / 3300 rpm ** 140 kW (190 mhp) / 3300 rpm
<b>Continuous rating output at crankshaft</b>	116 kW (158 mhp) / 3100 rpm
<b>Displacement</b>	3.455 L (211 cu in)
<b>Bore x stroke</b>	100 mm x 110 mm (3.94 in x 4.33 in)
<b>Cylinders</b>	4 in line
<b>Combustion system</b>	Direct injection
<b>Aspiration</b>	Turbocharged with intercooler
<b>Starting system</b>	Electrical starting 12 V
<b>Alternator</b>	12 V - 80 A
<b>Cooling system</b>	Fresh water cooling by centrifugal fresh water pump and rubber impeller seawater pump
<b>Lubrication system</b>	Enclosed, forced lubricating system
<b>Direction of rotation (crankshaft)</b>	Counter clockwise viewed from flywheel side
<b>Dry weight without gear</b>	365 kg (805 lbs)
<b>Environmental</b>	EU RCD, BSO II, EMC
<b>Engine mounting</b>	Rubber type flexible mounting

NOTE: Fuel condition: Density at 15°C = 0.842g/cm<sup>3</sup>; 1 mhp = 1 PS = 0.7355 kW = 0.9863 bhp

\* Fuel temperature 25°C at the inlet of the fuel injection pump (ISO 3046-1)

\*\* Fuel temperature 40°C at the inlet of the fuel injection pump (ISO 8665 : 2006)

**Dimensions** (For detailed line-drawings, please refer to our web-site: [www.yanmarmarine.com](http://www.yanmarmarine.com))

**Rear view**

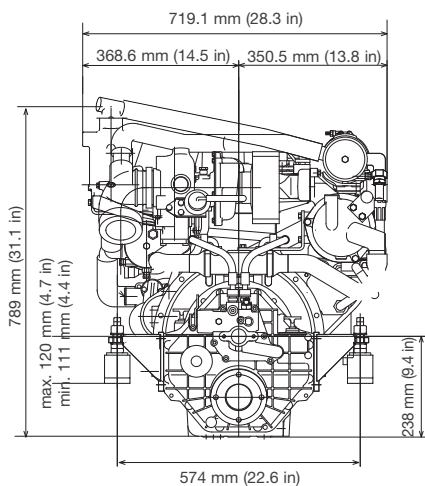

**Right side view**

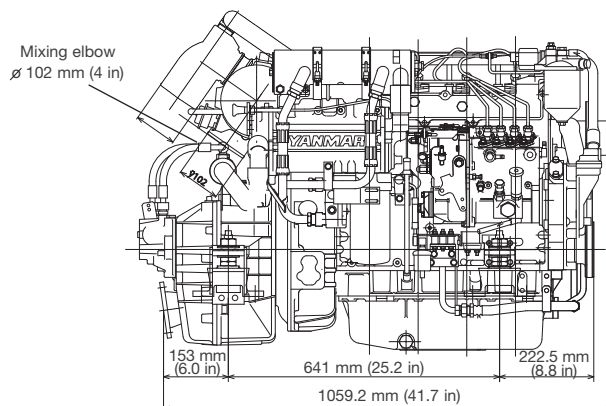

4LHA-DTP with ZF63A marine gear

## Performance Curves (Output is according ISO 8665 - Output includes +/- 3% tolerance)

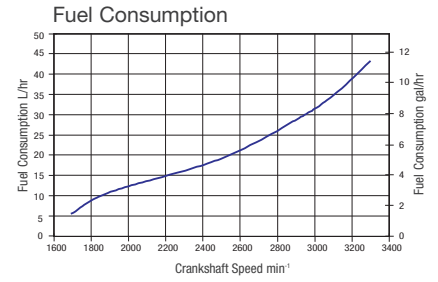
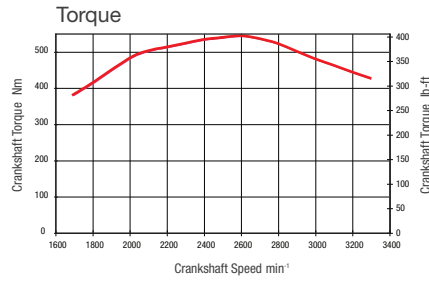
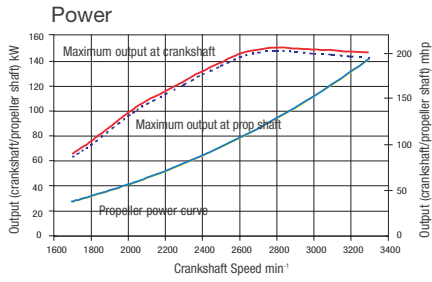

## Marine Gears \*\*\*

Model	KMH50A				ZF63A			
Type	8° down hydraulic				8° down hydraulic			
Dry weight	44 kg (97 lbs)				28 kg (62 lbs)			
Reduction ratio (fwd/asn)	1.67/1.67	2.13/2.13	2.43/2.43	1.22/1.22	1.56/1.58	2.04/2.02	2.52/2.54	2.68/2.71
Propeller speed (fwd/asn)	1976/1976	1549/1549	1358/1358	2714/2716	2111/2085	1620/1636	1308/1301	1230/1218
Direction of rotation (propeller shaft - fwd)	Clockwise & counter clockwise viewed from flywheel side				Clockwise & counter clockwise viewed from flywheel side			
Dry weight engine and gear/drive	409 kg (902 lbs)				393 kg (866 lbs)			

\*\*\* Other marine gearboxes and configurations available upon request. Contact your local supplier for more information.

## Instrument Panels

### New C-type Panel

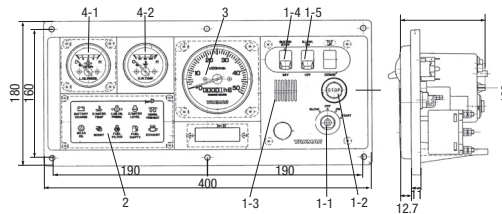

Function	Type of instrument panel
	New C-type Panel
① <b>Switch unit</b>	
1-1 Key switch for GLOW/OFF/ON/START (4-position switch)	O
1-2 Engine stop switch	O
1-3 Alarm buzzer (C.W. Temp., L.O. Pressure)	O
1-4 Alarm buzzer stop switch	O
1-5 Illumination switch for meters	O
② <b>Alarm lamp unit</b>	
Battery not charging	O
C.W. high temperature	O
L.O. low pressure	O
Boost pressure high (for 4LHA-STP)	O
③ <b>Tachometer with hour meter</b>	O
④ <b>Sub meter unit</b>	
4-1 L.O. pressure meter	O
4-2 C.W. Temperature meter	O
4-3 Boost meter (turbo)	X
⑤ <b>Quartz clock</b>	X

Note: O = Equipped on panel X = Not equipped on panel

## Accessories

### Standard Package

- Sensor for various panels
- Exhaust/water mixing elbow (L-type)
- Alternator 12 V - 80 A

### Optional

- Flexible mounts
- Exhaust/water mixing elbow, U-type (high riser)
- New C-type instrument panel
- Dual station Y harness
- Dipstick for opposite side
- Air venting device for cooling water tank

Texts and illustrations are not binding. Yanmar Marine reserves the right to introduce adaptations without prior notification.

4LHA-DTP Version: 2010-04